

Welcome



5 May 2015 Sea Ice Prediction Network (SIPN) Webinar

*“Observations of Arctic snow and sea ice thickness
from satellite and airborne surveys”*

Presented by Nathan Kurtz, NASA Goddard Space Flight Center

<http://www.arcus.org/sipn>

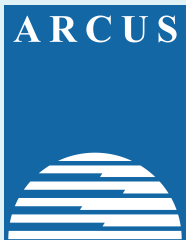

Webinar Guidelines

- ❖ **All participants have been muted upon entry to this webinar.**
- ❖ **Please select “All Attendees” in the Chat Window to share your comments and questions.**
- ❖ **The webinar will be open for questions and comments following the presentation.**
(A facilitator will ask the question for you.)
- ❖ **If you are having technical difficulties, please contact Judy Fahnestock (judy@arcus.org).**
- ❖ **Today’s presentation will be archived and available on the SIPN Webinars webpage:**
<http://www.arcus.org/sipn/meetings/webinars>.

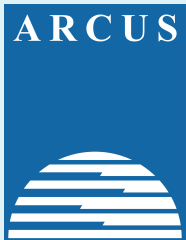

RETURN Audio Mute Me Participants Chat Q&A Options

Viewing Jessica Rohde's desktop

Click to open Chat Window

Click to see Participants



Navigating on WebEx

Arctic Research Consortium of the United States

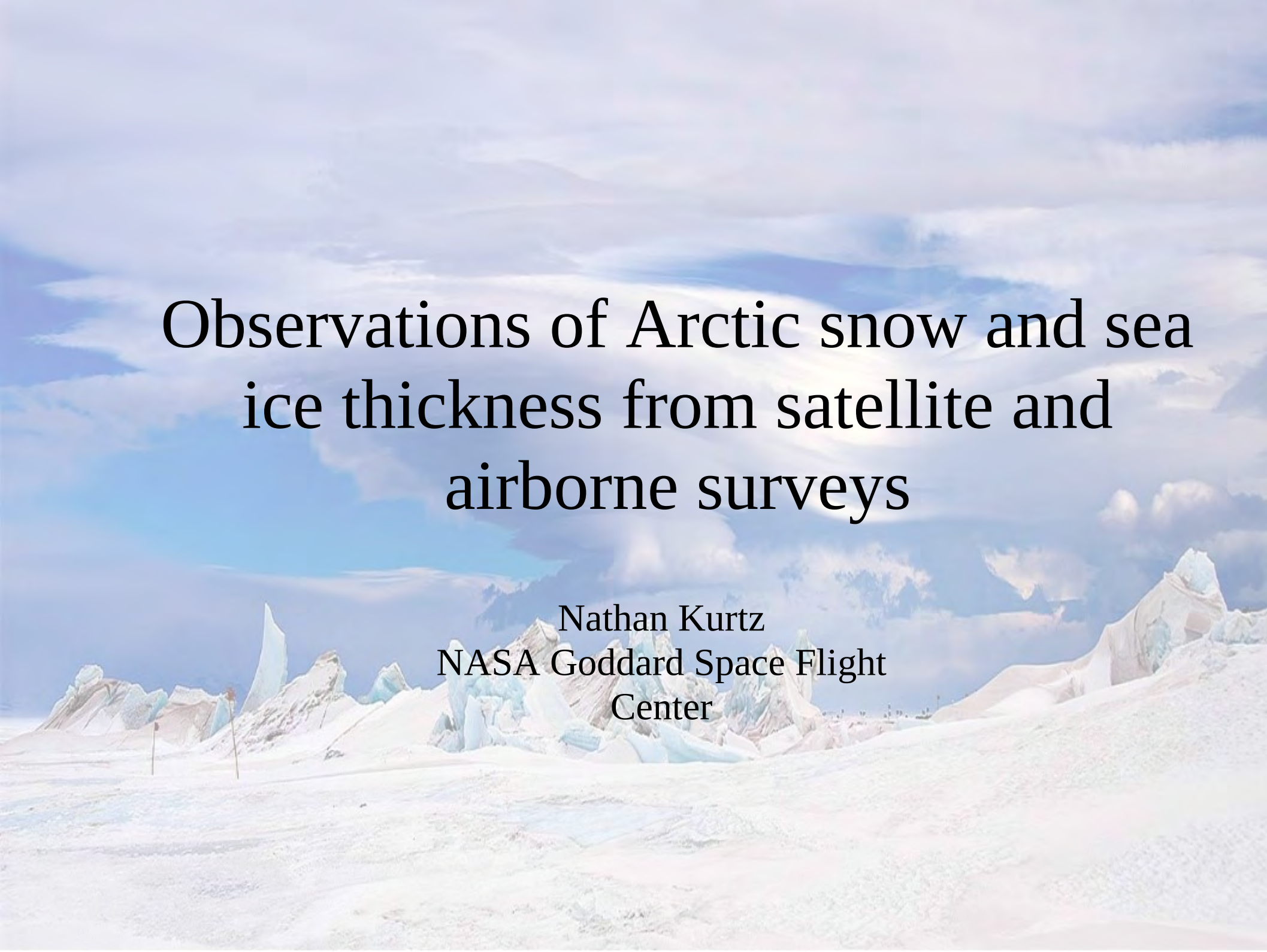
A wide-angle photograph of an Arctic landscape. The foreground is a vast, flat expanse of snow and ice, with some small, dark markers or stakes visible. In the middle ground, there are several large, jagged icebergs or chunks of ice, some showing a blueish tint. The background is a vast, open sky filled with soft, white and grey clouds, with a hint of a blue horizon. The overall scene is desolate and cold.

Observations of Arctic snow and sea ice thickness from satellite and airborne surveys

Nathan Kurtz
NASA Goddard Space Flight
Center

Decline in Arctic sea ice thickness and volume

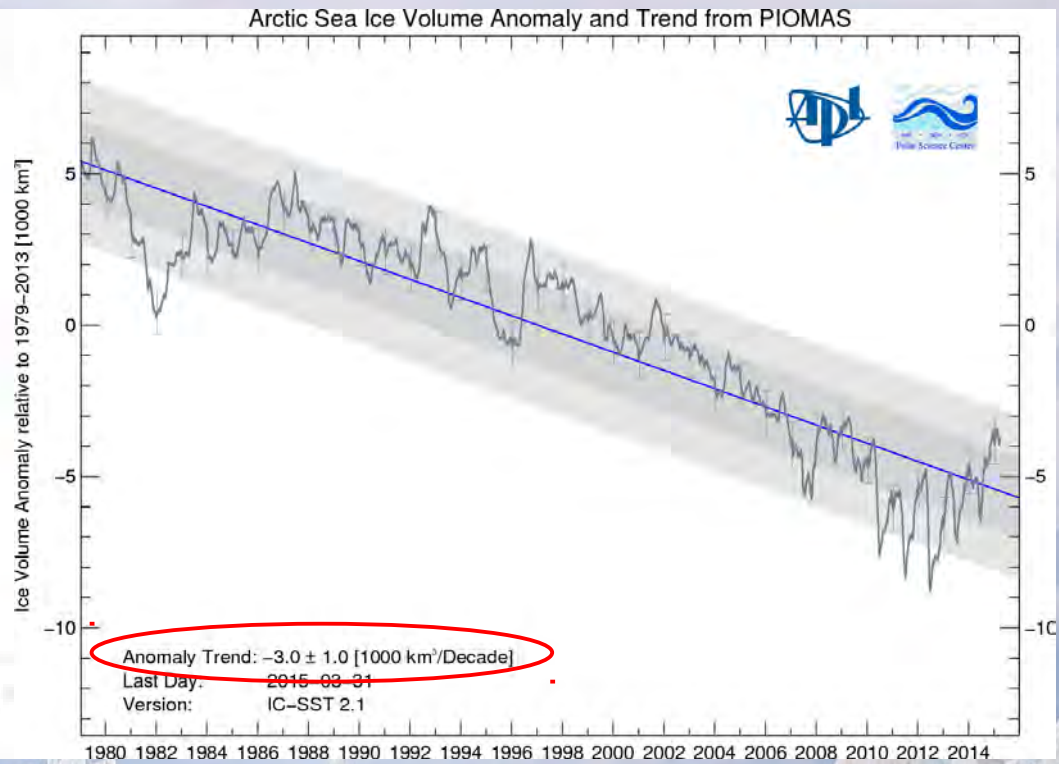
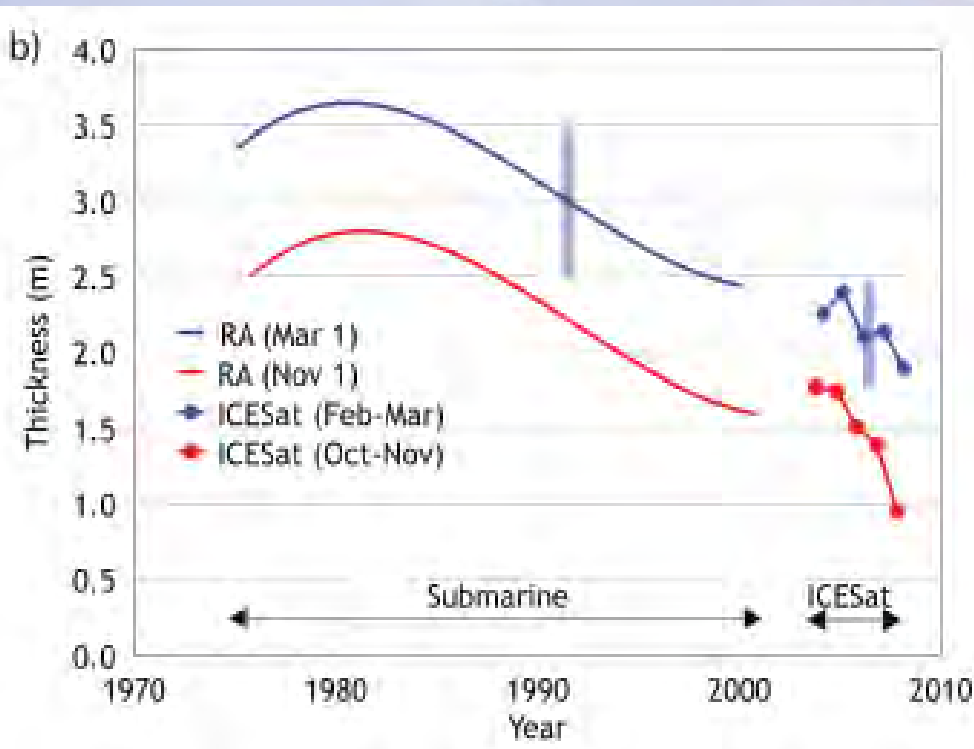

Kwok et al. (2009)

Submarine and satellite records show large decline of Arctic sea ice thickness over the last three decades

Model results show $\sim 3000 \text{ km}^3/\text{decade}$ decline since 1979

Major results on the retrieval of sea ice thickness and volume from satellite altimetry

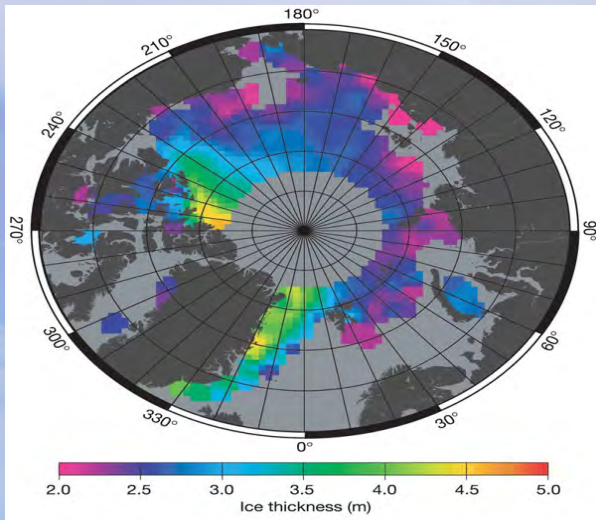

ERS-1 and ERS-2 thickness fields
(1993-2001) from Laxon et al., 2003

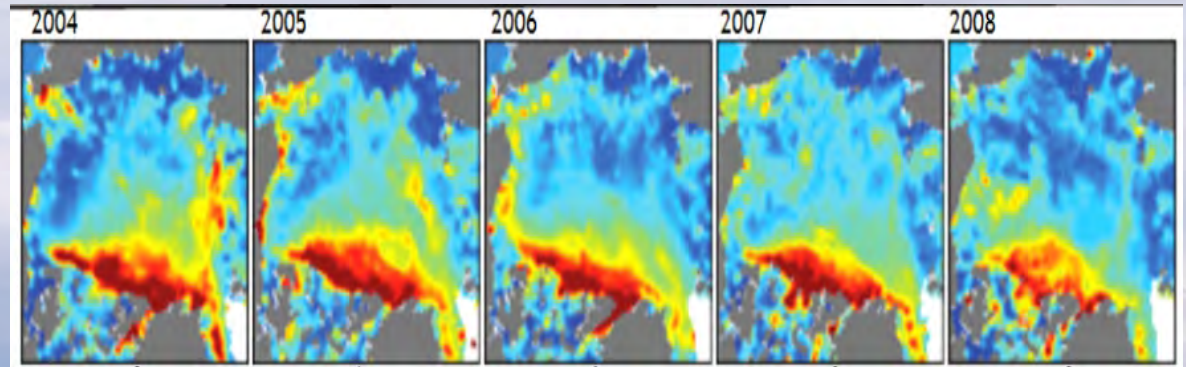

ICESat thickness fields (2004-2008) from
Kwok et al., 2009

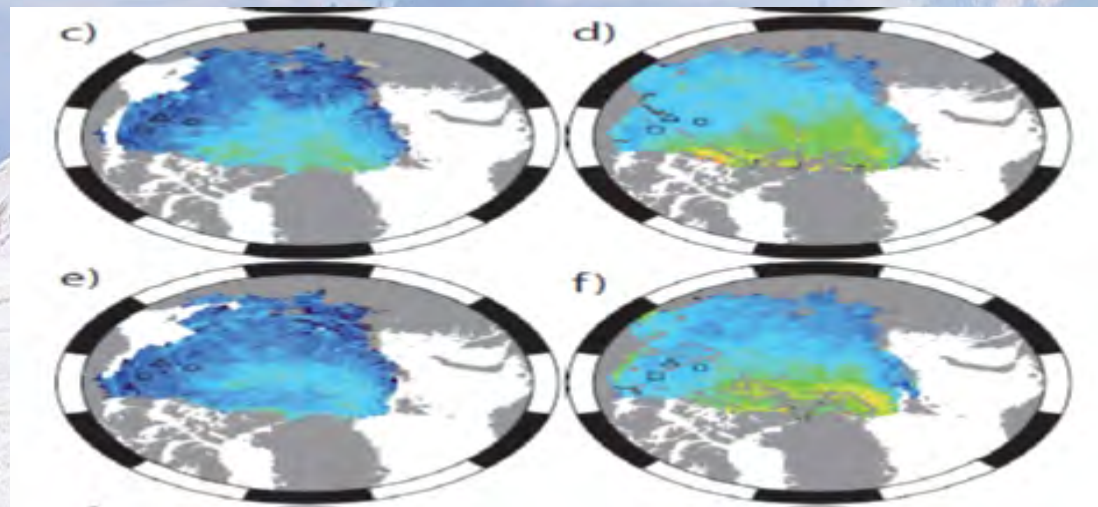

CryoSat-2 thickness fields (2010-2012) from Laxon et al., 2013

Outline of major challenges

- There is still much debate about existing uncertainty and biases in the altimetry data records since 1 cm error in freeboard corresponds to ~ 10 cm error in ice thickness
- Major uncertainty sources of elevation and freeboard retrieval from altimeters
 - Laser: open water identification, clouds/forward scattering
 - Radar: waveform tracking, absorption/ penetration, snow and ice backscatter characteristics, off-nadir scattering
- Snow depth: needed for thickness retrievals, also impacts propagation speed of radar
- Sea ice and snow density: impacts sea ice thickness retrievals, propagation speed of radar

Laser and radar altimetry for sea ice studies

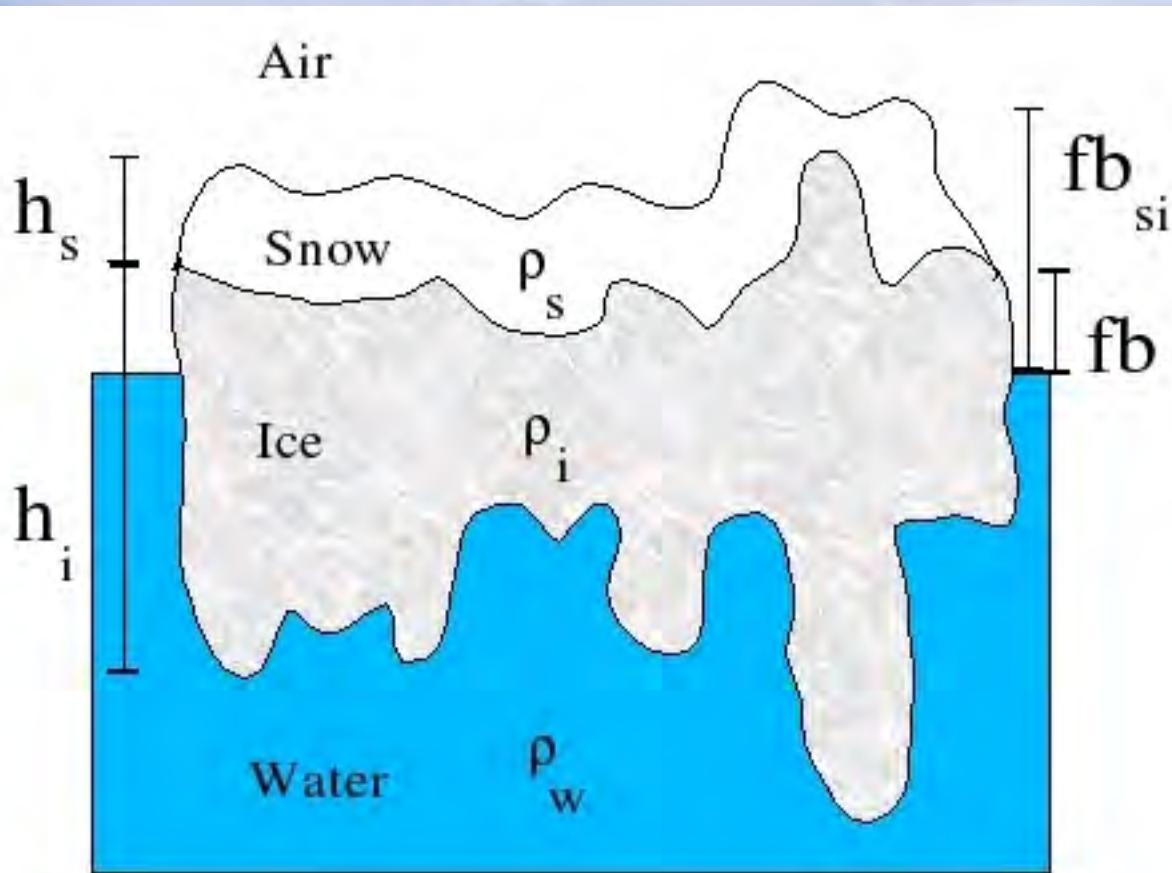

Laser and radar altimetry are used to find the freeboard

Archimedes principle: assuming hydrostatic balance the buoyant force from the displaced water equals the weight of the snow and ice column

$$\rho_s h_s + \rho_i h_i = \rho_w h_i - \rho_w fb$$

Rearranging gives ice thickness:

$$h_i = \frac{\rho_s - \rho_w}{\rho_w - \rho_i} h_s + \frac{\rho_w}{\rho_w - \rho_i} fb_{si}$$

Linking satellite laser and radar altimetry through airborne and in-situ measurements

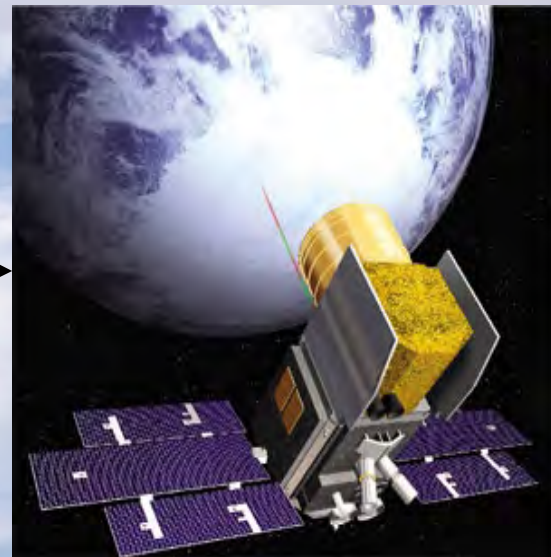

- Producing a reconciled satellite data set requires consistent methods and assumptions be used in determination of sea ice thickness
- Need for three tiered approach: 1. Small-scale in-situ data collection. 2. Regional-scale aircraft measurements with overflights of in-situ surveys to quantify uncertainties. 3. Global-scale satellite data with coincident airborne measurements to quantify uncertainty and improve retrieval methodology.
- NASA's Operation IceBridge mission offers unique solution to reconcile the satellite laser and radar altimeter records by directly comparing fundamental measurements made by the altimeters: surface elevation and freeboard
- To date, 16 overflights of in-situ measurement sites by IceBridge
- Spatial and temporal overlap between IceBridge (2009-2019) and ICESat (2003-2009), CryoSat-2 (2010-present), and ICESat-2 (2017) satellite missions provides coverage to calibrate and assess the satellite records

Seven years of IceBridge measurements

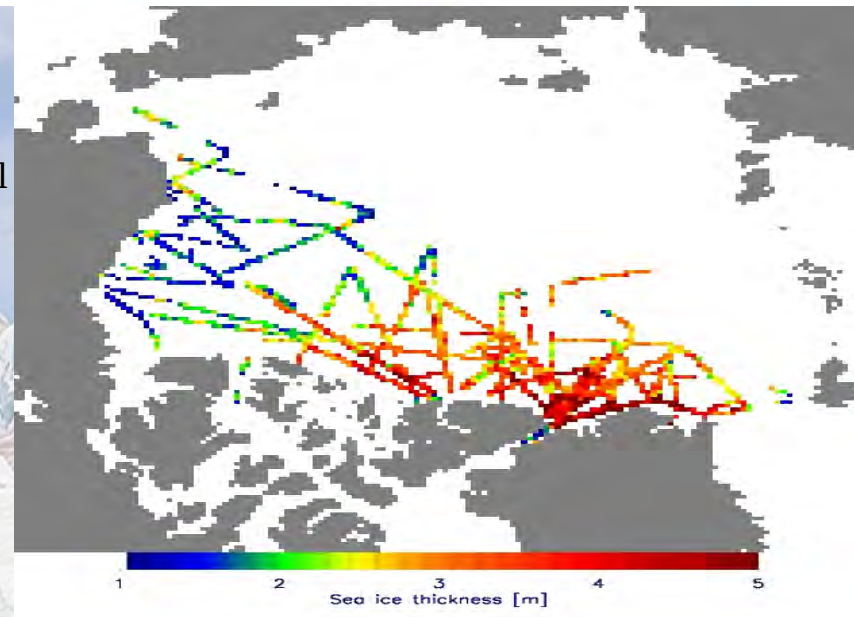
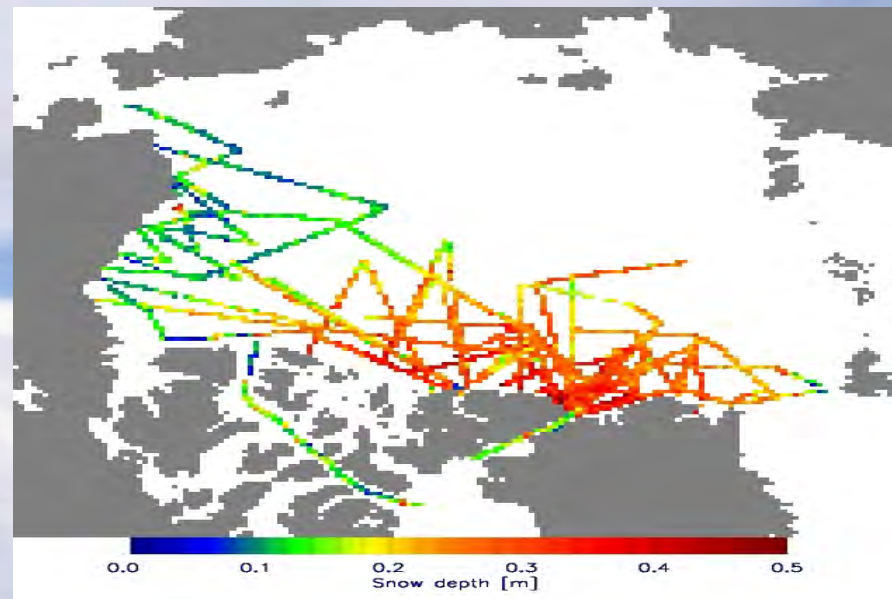
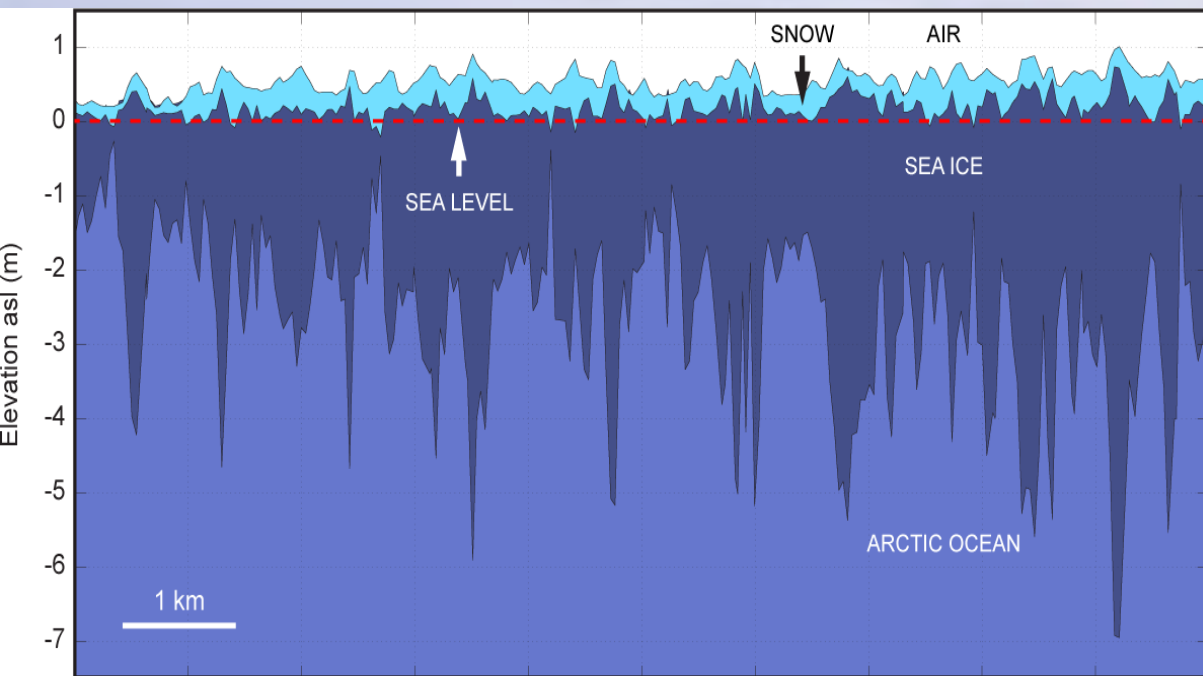

1. Freeboard from laser altimetry data (Airborne Topographic Mapper) and optical imagery for lead detection (Digital Mapping System)

2. Snow depth from University of Kansas' 2-8 GHz FMCW snow radar

3. Sea ice thickness from freeboard and snow depth data sets and assumption of hydrostatic balance

Operational sea ice data products at 40 m resolution distributed via NSIDC:

<http://nsidc.org/data/idcsi2.html>

Airborne laser altimetry mapping of sea ice

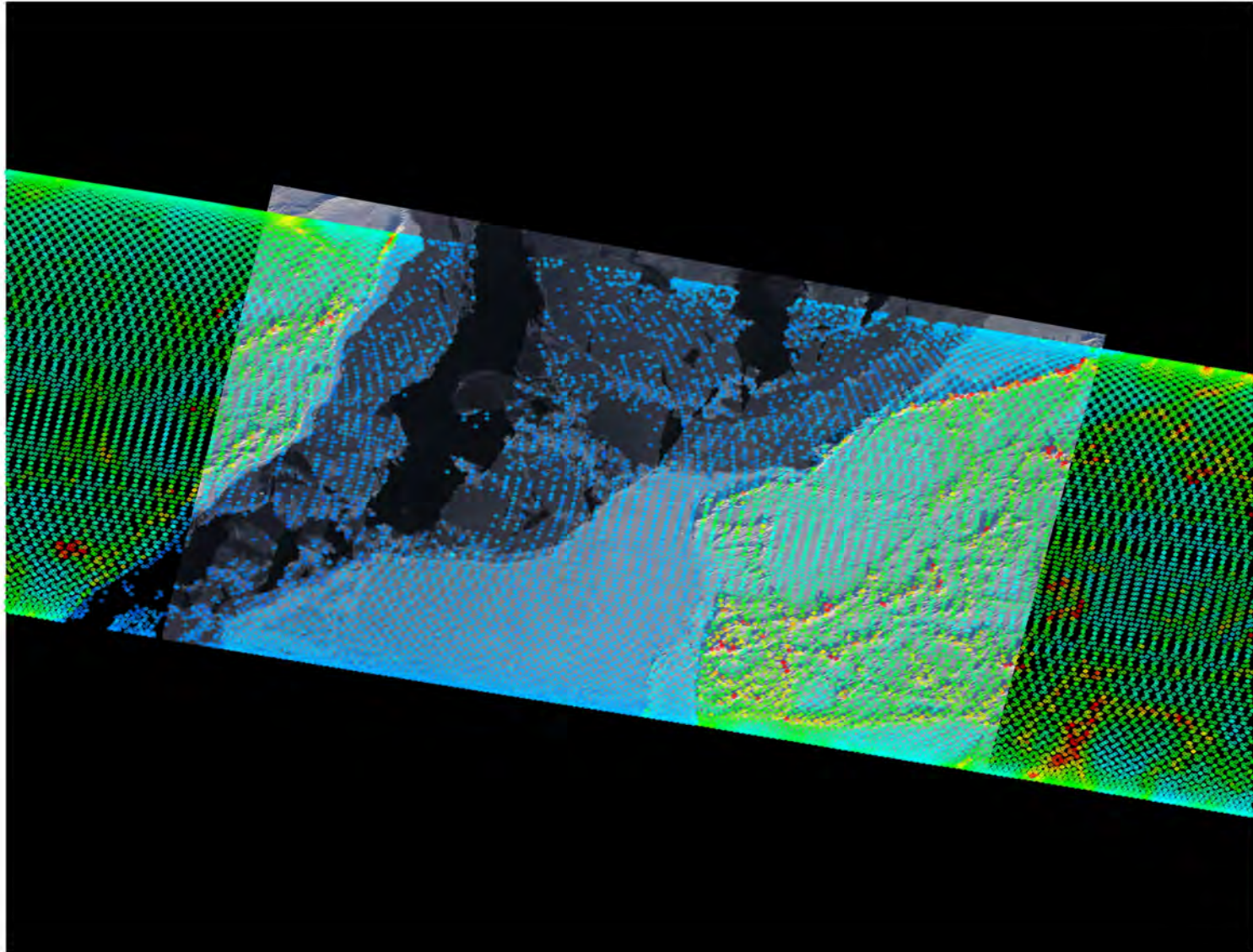

Lead identification and classification

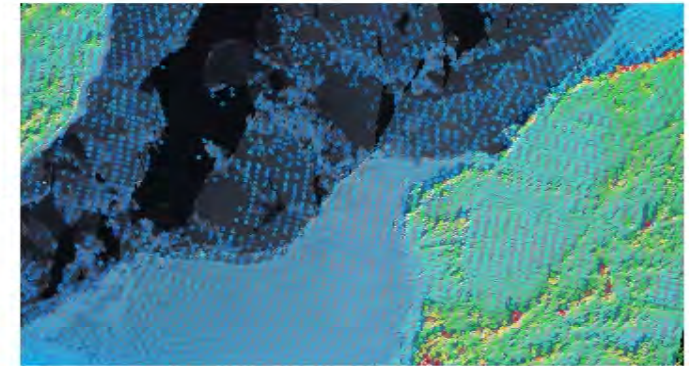
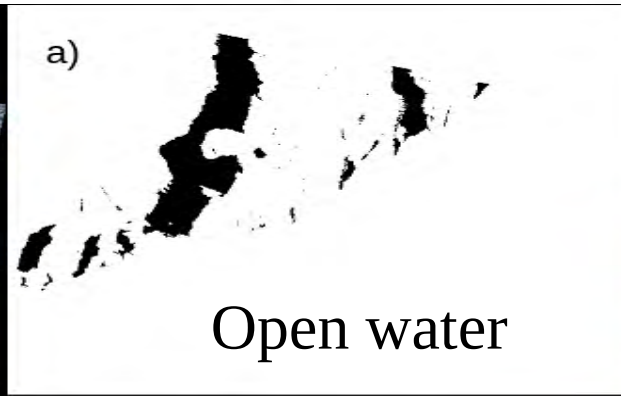
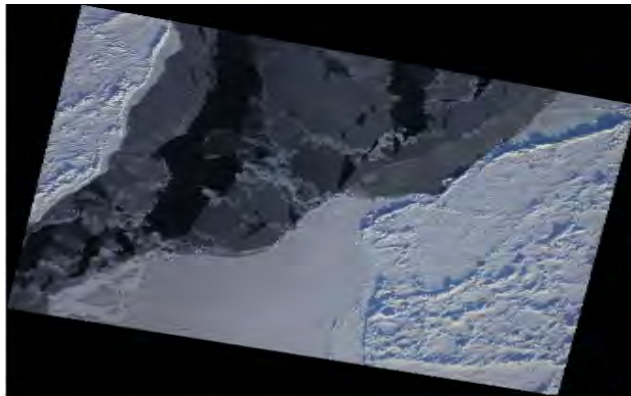

19
18
17
16
15
14
13
12
11
1

SILDAMS (Onana et al., 2013) : A minimal signal approach using affine transformations on DMS images

Extracts and classifies leads into open water and two thin ice types

Compensation for freeboard profile bias due to use of ice covered leads as SSH tie points and also the loss of laser data over leads/thin ice

New narrow scan laser minimizes loss of laser returns over leads/thin ice

Freeboard retrieval

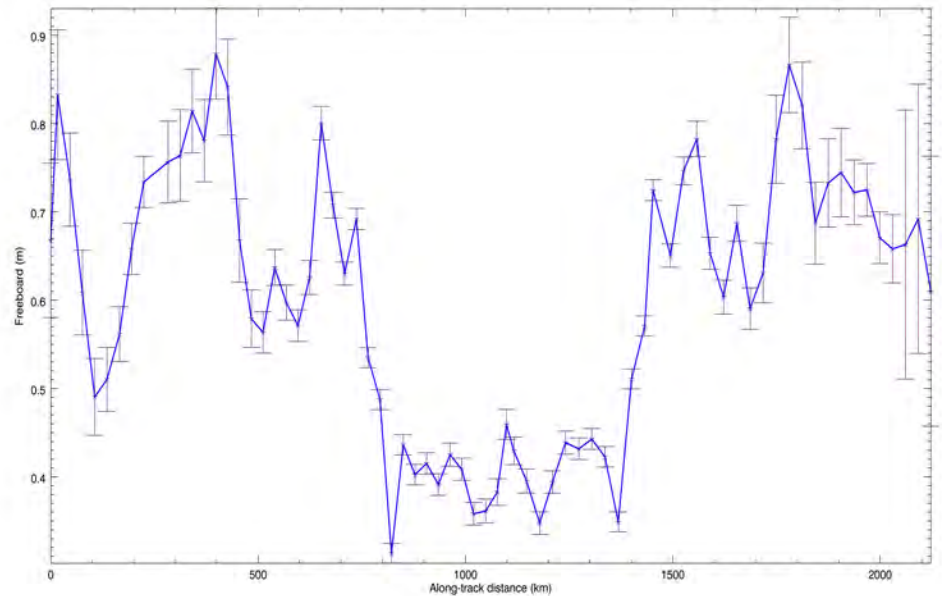
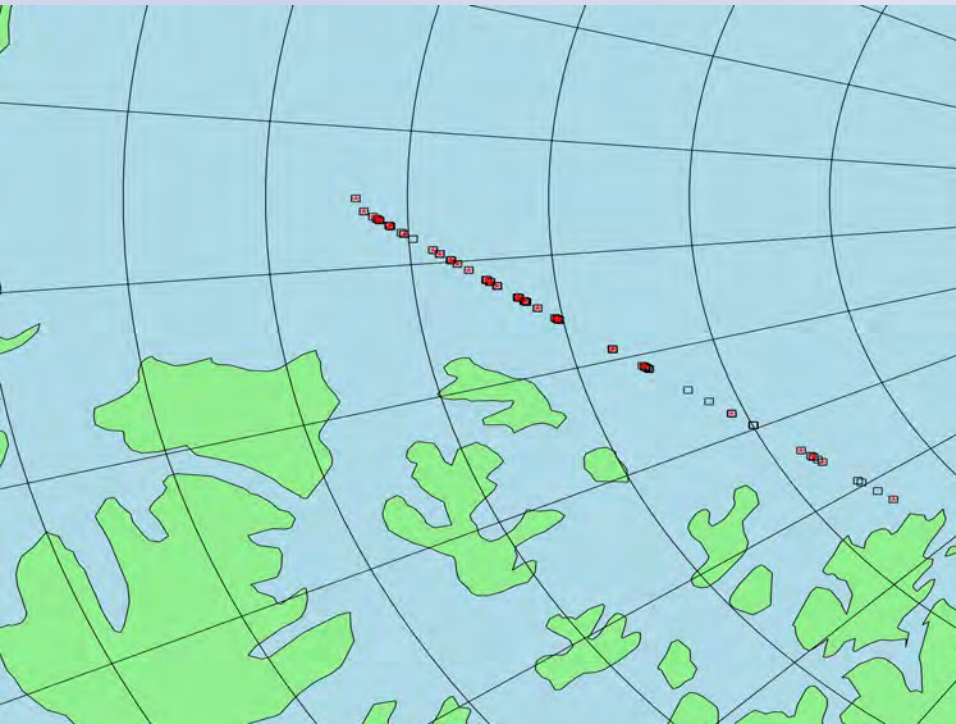

- Leads are only encountered sporadically along each flight track
- Uncertainty in sea surface height increases with distance from each sea surface observation point
- Ordinary kriging used to interpolate the sea surface height along the flight track and determine the associated freeboard uncertainty

IceBridge snow radar

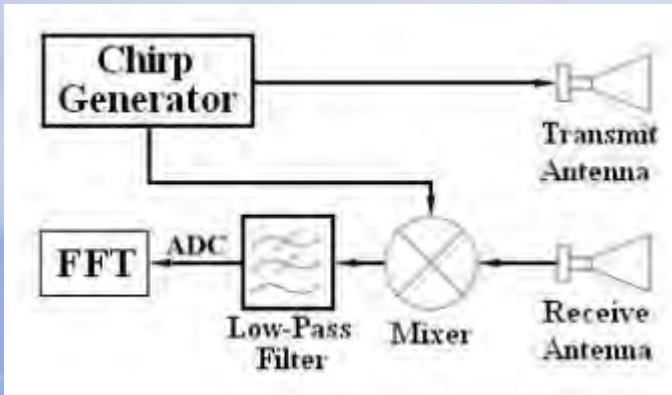

Basic frequency modulated continuous wave (FMCW) radar components

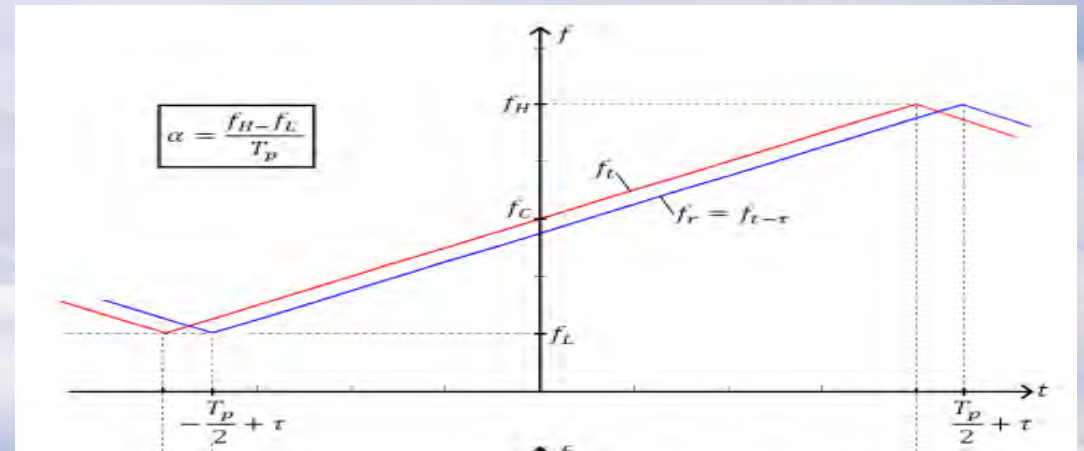

An oscillator produces a pulse which increases in frequency linearly in time. The transmit and receive signals are multiplied in a mixer, and the range to target is measured by the frequency difference.

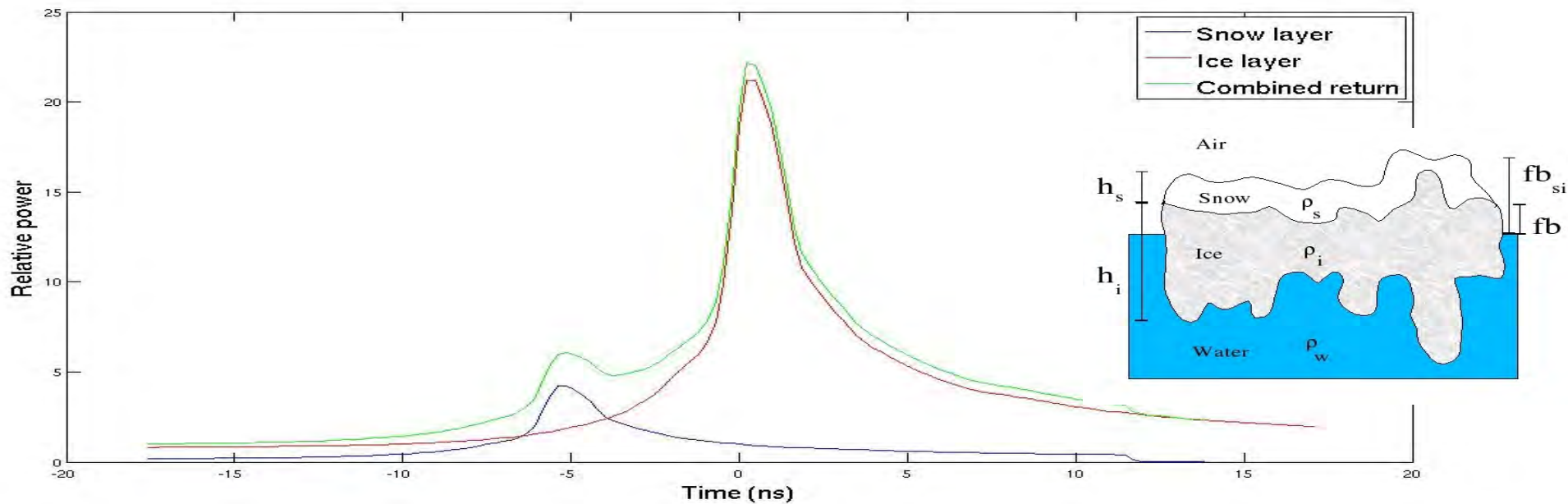

Snow depth retrievals through waveform fitting: model

Physically, the radar return is due to combined effect of the instrument point target response (transmit pulse), impulse response, surface height distribution, backscatter profiles of snow and ice, plus the coherent and incoherent surface scattering contributions

$$\Psi(\tau) = P_t(\tau) \otimes (I_{incoh}^{snow}(\tau) \otimes p_{snow}(\tau) \otimes v_{snow}(\tau) + I_{incoh}^{snow-patch} + I_{incoh}^{ice}(\tau) \otimes p_{ice}(\tau) \otimes v_{ice}(\tau) + \otimes I_{coh}^{ice}(\tau) + I_{incoh}^{ice-patch}) + P_{coh}^{snow-patch}(\tau) + P_{coh}^{ice-patch}(\tau)$$

Point target response determined from sea ice leads

$$I(\tau) = \sum_{k=-(N_b-1)/2}^{(N_b-1)/2} H\left(\tau + \frac{\eta h \xi_k^2}{c}\right) \int_0^{2\pi} d\theta G(\theta) \sigma(\theta) \sum_{n=0}^{N_b} D(\theta)$$

Surface height distribution determined from ATM laser altimeter

$$v(\tau) = \left\{ \begin{array}{l} 0, \tau < -\frac{2h_s}{c_{snow}} \\ \sigma_{surf-snow}^0 \delta\left(\tau + \frac{2h_s}{c_{snow}}\right) + \sigma_{vol-snow}^0 k_{e-snow} \exp\left[-c_{snow} k_{e-snow} \left(\tau + \frac{2h_s}{c_{snow}}\right)\right], \\ 0 < \tau \leq \frac{-2h_s}{c_{snow}} \\ \sigma_{surf-ice}^0 k_{t-snow}^2 \exp\left[-k_{e-snow} h_s / 2\right] \delta(\tau) \\ + \sigma_{vol-ice}^0 k_{e-ice} \exp\left[-k_{e-snow} h_s / 2 - c_{ice} k_{e-ice} \tau\right], \\ \tau \geq 0 \end{array} \right.$$

Snow depth retrieval from waveform fitting method

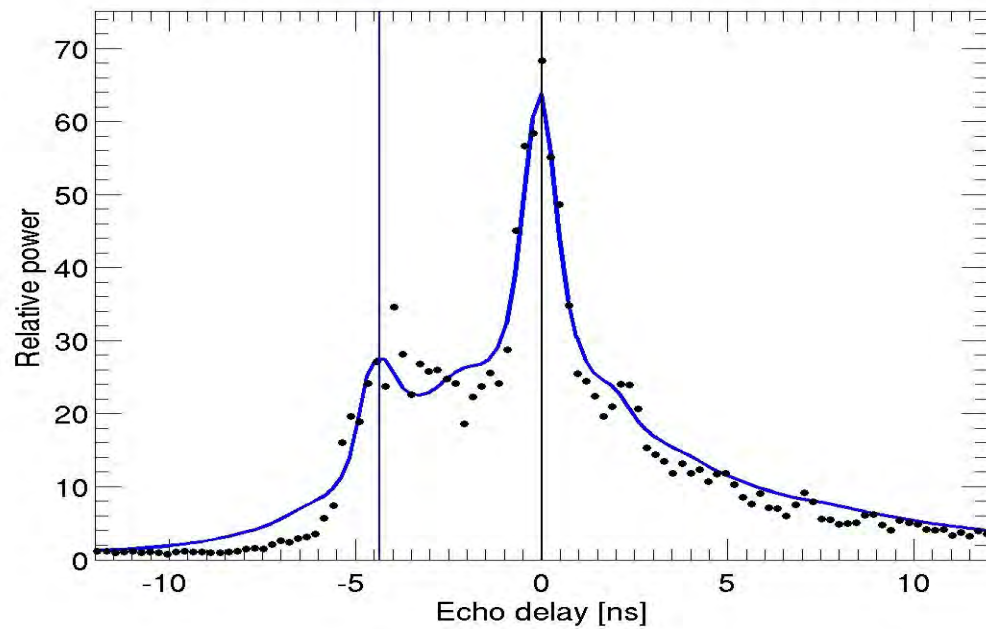
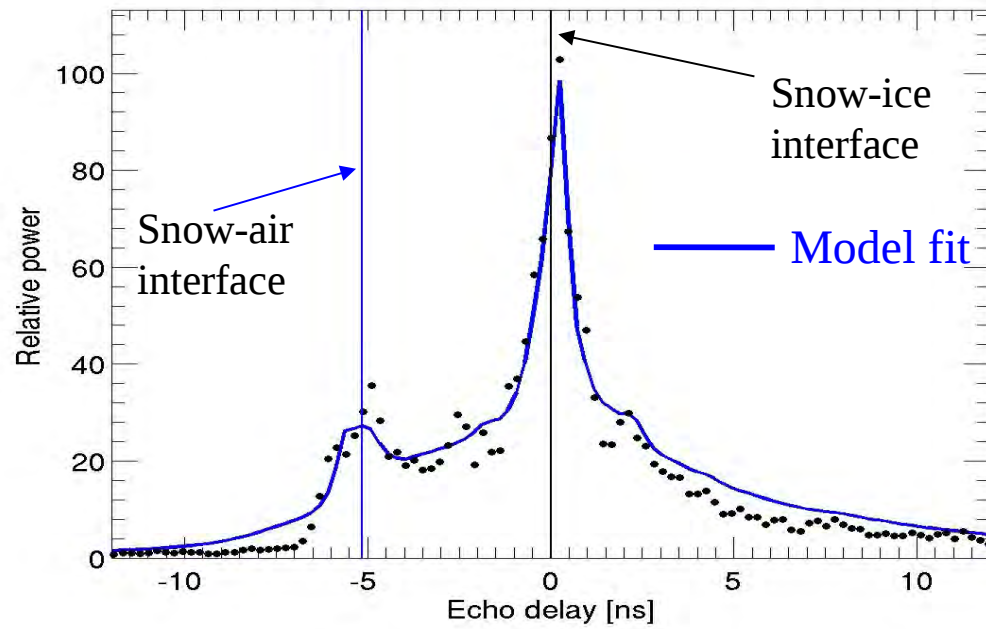

Interdecadal changes in snow depth on Arctic sea ice

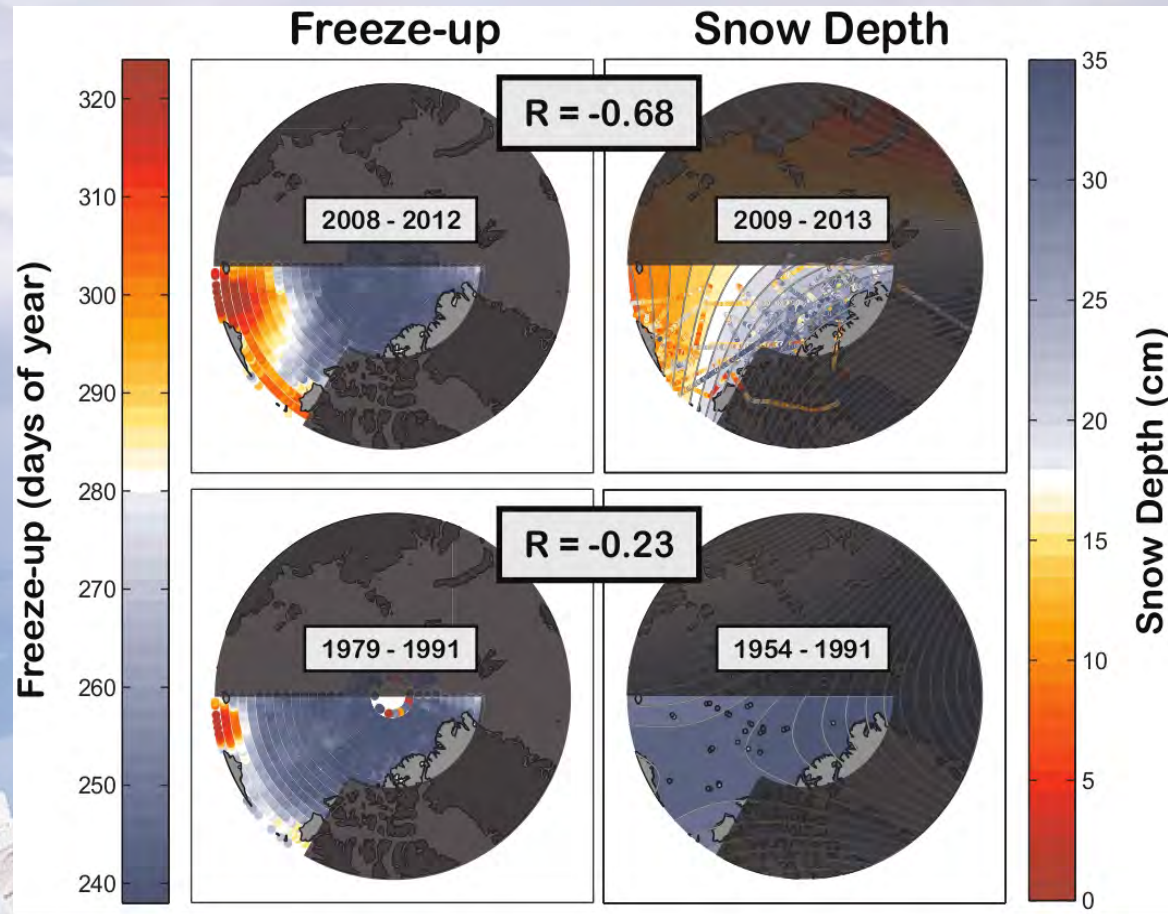
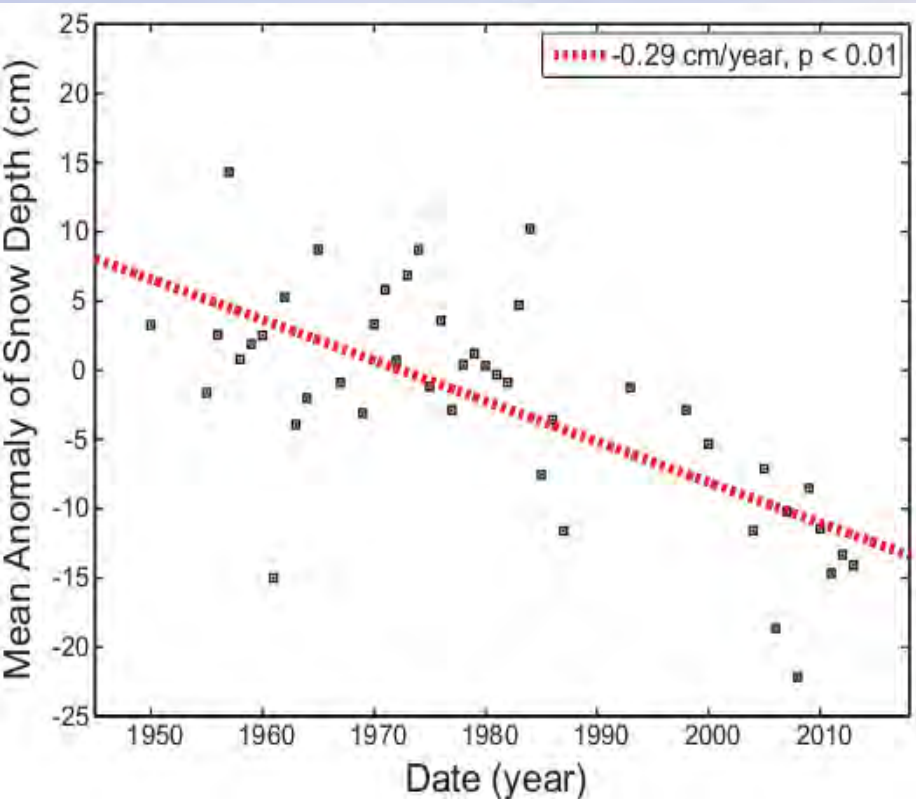

Webster et al., 2014

Large changes in snow depth on Arctic sea ice in the Western Arctic. Decadal-scale data from Soviet drifting stations (1950-1987), ice mass balance buoys (1993-2013), IceBridge snow radar (2009-2013). Changes are correlated to later freeze-up dates in the Beaufort and Chukchi Seas because most snow accumulation occurs in September and October.

IceBridge reprocessing

Version 2 reprocessing

2009-2013 data to be sent to NSIDC in next few weeks

Significantly reduced uncertainties due to improved sea surface height knowledge: new tide model (TPXO8.0), mean sea surface height model (DTU 10), dynamic atmospheric correction (MOG2D)

Fixed known errors identified in previous processing run: scan angle bias correction, tide errors, footprint spacing

Improved coverage utilizing both narrow and wide-scan ATM

Version 3 reprocessing: planned in coming months

Full waveform processing (Yi et al., 2015) to identify leads in areas flown in darkness, expanding coverage

New snow depth retrievals using waveform fitting – automatically adapts to instrument changes and sidelobe artifacts, enables retrieval of new parameters

Version 2 freeboard uncertainty

Version 1, Arctic 2010

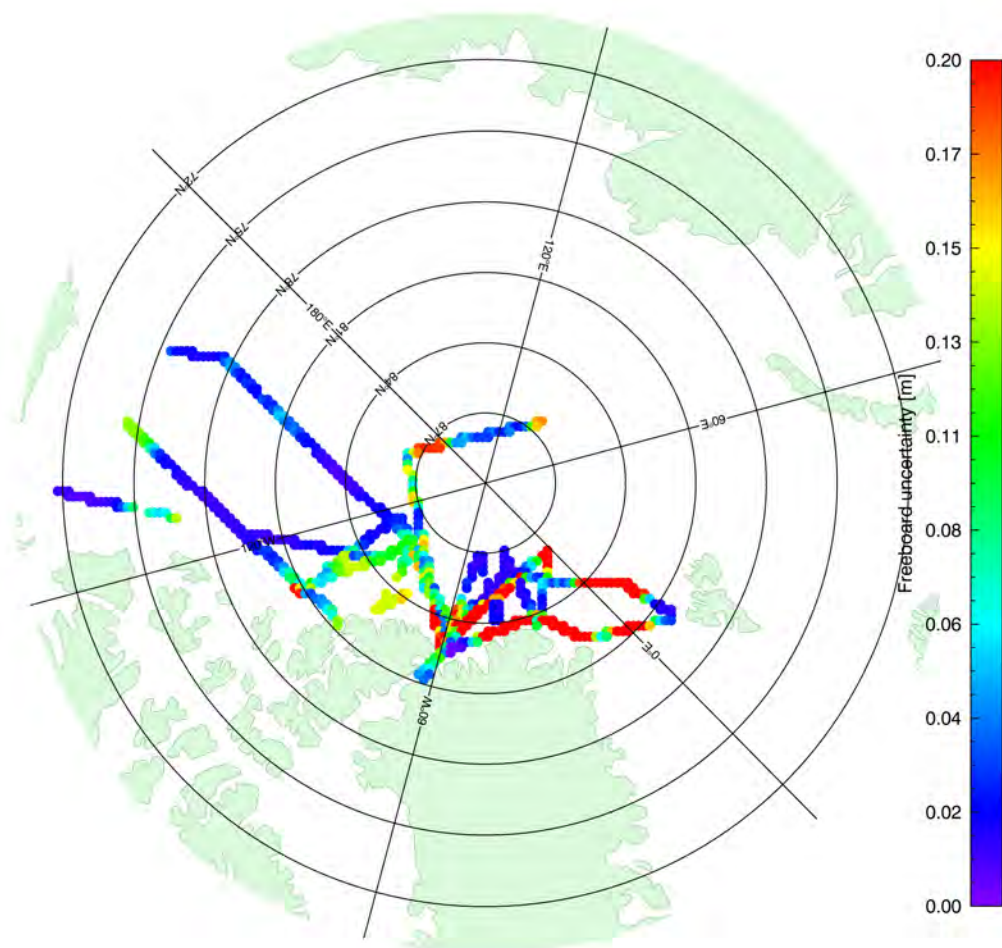

Version 2, Arctic 2010

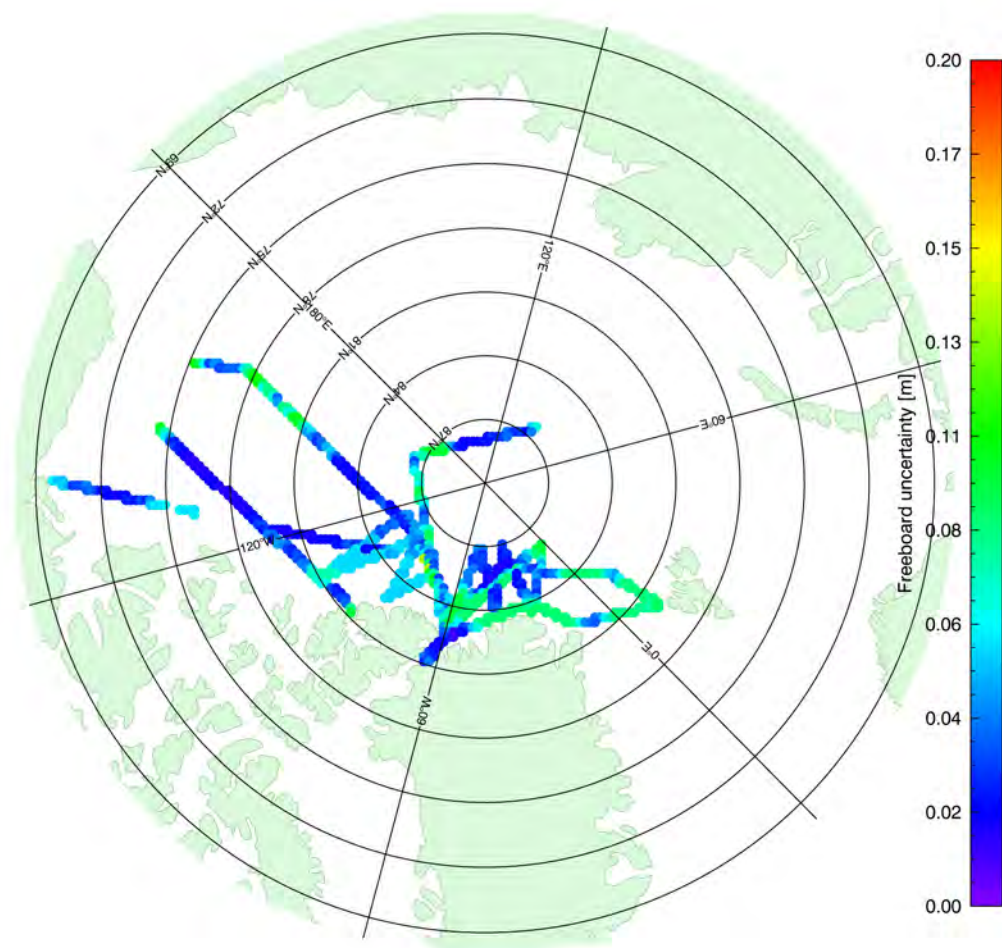

Availability of near real-time data products for support of seasonal sea ice forecasting

CryoSat-2 sea ice thickness, March 2014

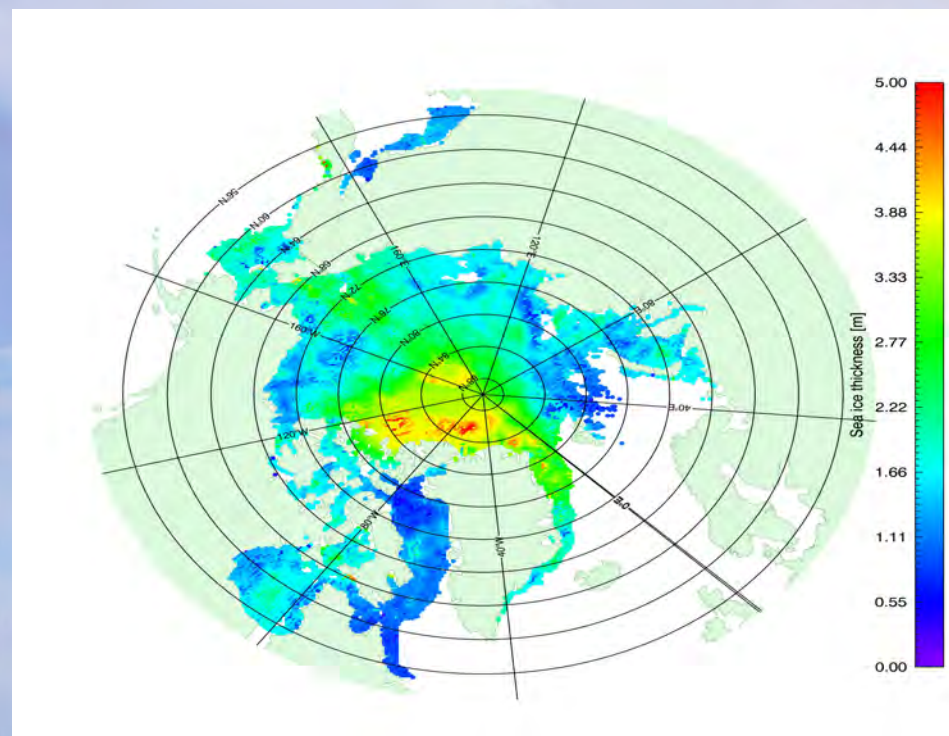

OIB sea ice thickness, March 2014

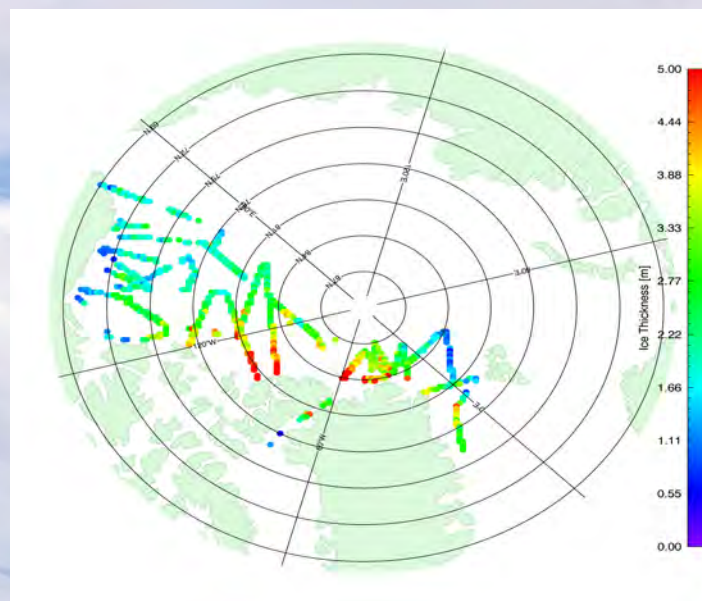

IceBridge quicklook data available since 2012, CryoSat-2 data newly available in 2014, data sets made available ~1 month after the completion of each Arctic IceBridge campaign

Near-real time CryoSat-2 sea ice thickness product expected in Fall 2015

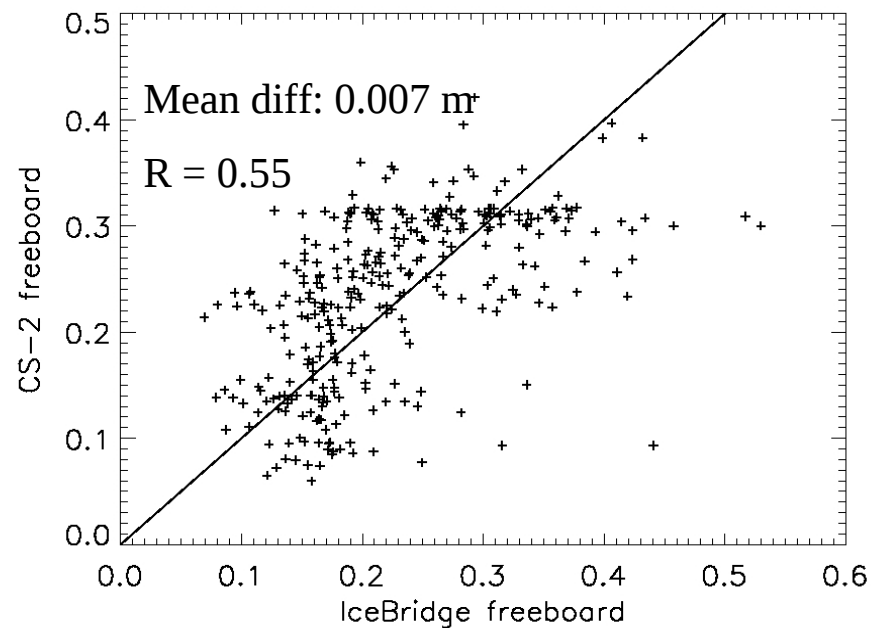

Motivation for availability of observational ice thickness data: improved model physics and predictive skill

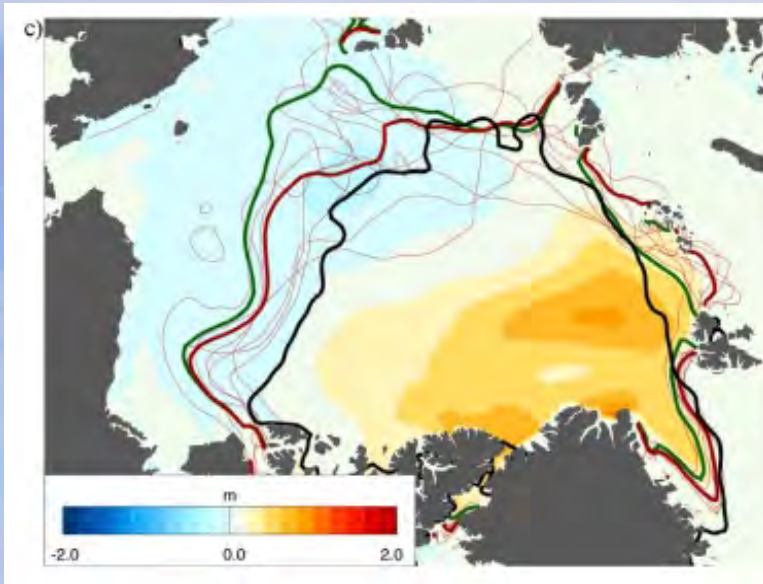

- Observed ice extent
- Model predicted ice extent, no assimilation
- Model predicted ice extent, with assimilation

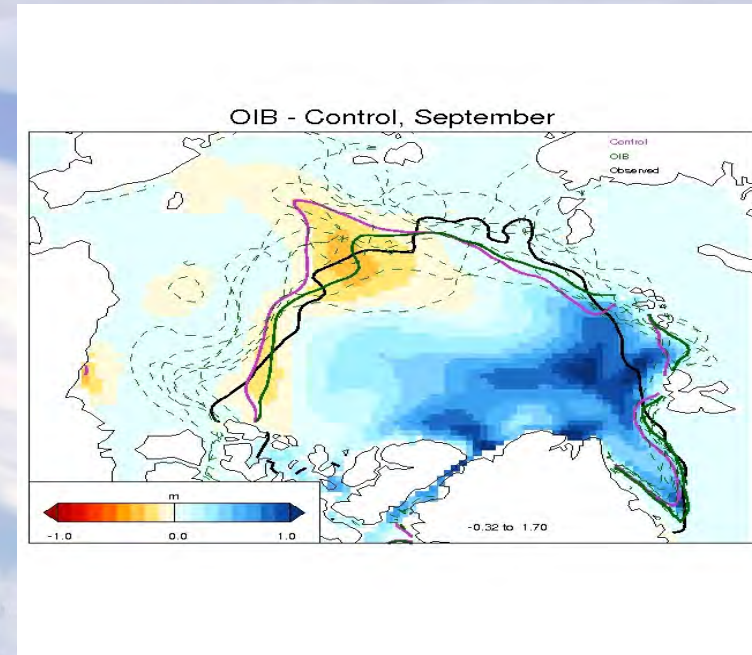

Lindsay et al., 2012

IceBridge quick look data and PIOMAS model simulations used for forecasting of the sea ice minimum using data assimilation

Incorporation of IceBridge thickness data slightly improved seasonal ice minimum prediction, but also demonstrated importance of weather and need for improved assimilation methods, and need to further improve model physics

CryoSat-2

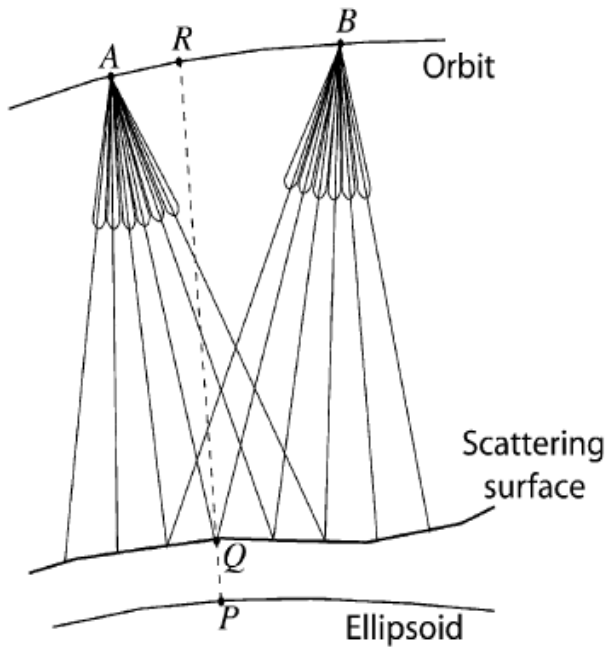

Wingham et al., 2006



Radar altimeter which uses unfocused SAR processing to separate each beam into 64 strips. All looks for an individual point are combined into a multi-looked echo or waveform.

Effective spatial resolution $\sim 380 \text{ m} \times 1.7 \text{ km}$

13.575 GHz center frequency, 320 MHz bandwidth

Major challenges for radar altimetry: waveform tracking

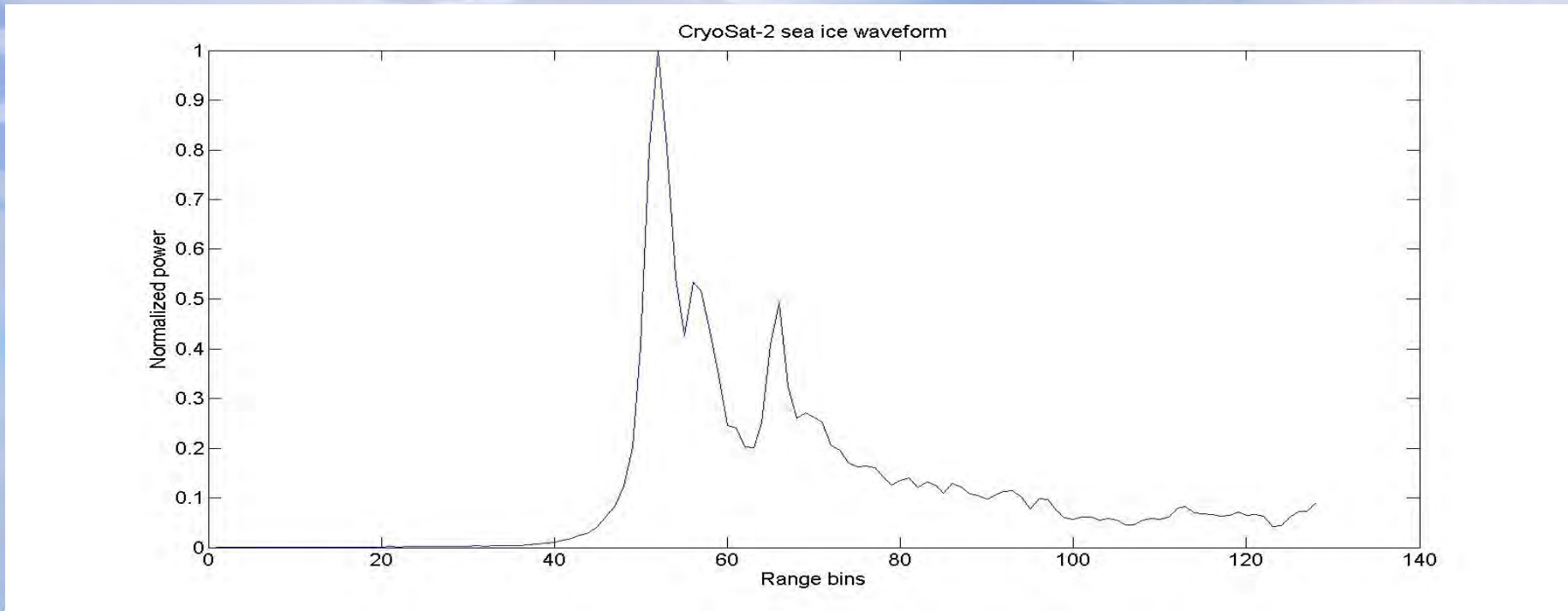

For CryoSat-2 an error of one range bin in the tracking procedure leads to an error of 23 cm and thickness error of 2.2 m

Most freeboard retrieval methods use an empirical constant threshold to track the return, e.g. 70% of the first peak power

Outlook on improved tracking methods

Sea ice floe

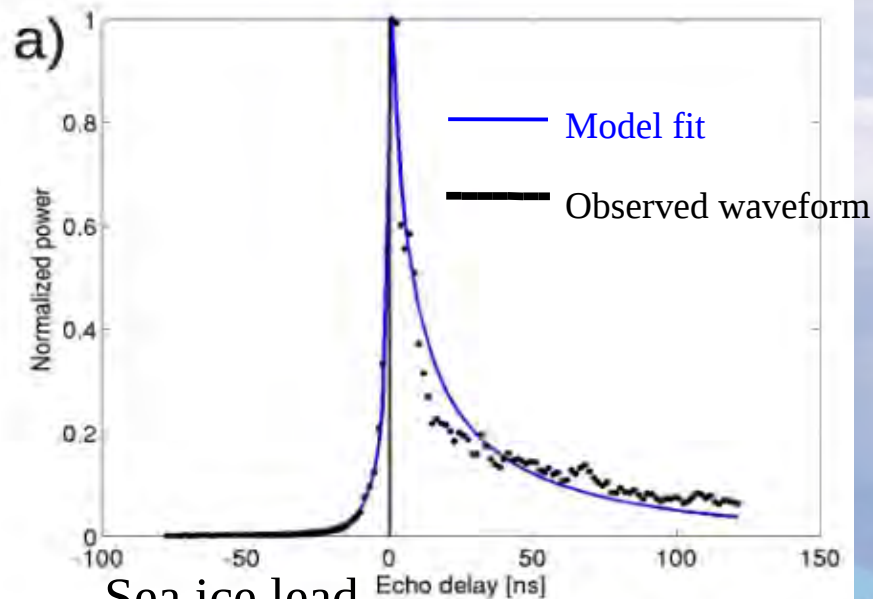

Sea ice lead

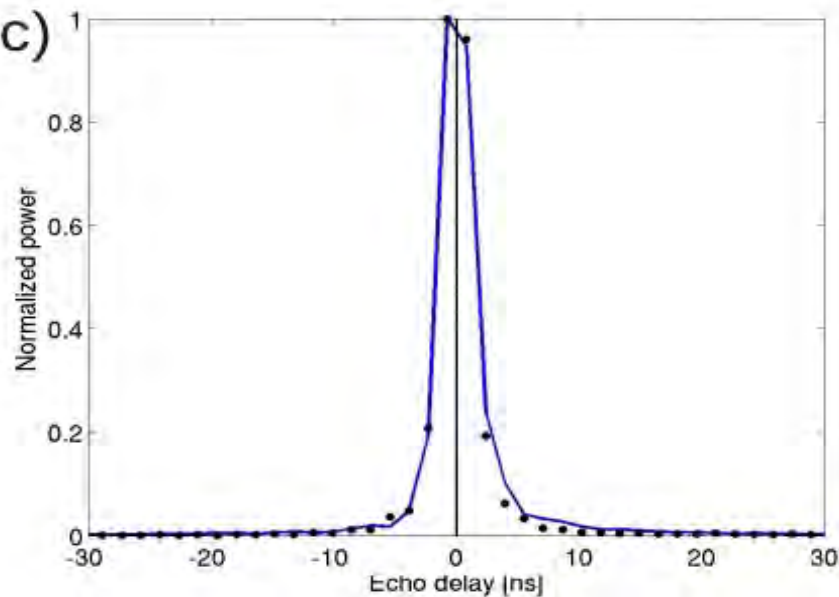

$$\Psi(t) = P_t(\tau) \otimes I(\tau) \otimes p(\tau) \otimes v(\tau)$$

Physically, the radar return is a convolution of 4 terms: transmit pulse, impulse response, surface height distribution, backscatter profiles of snow and ice

Improved tracking of waveforms needs to incorporate a more physical treatment of the return. Much more work can be done in this area to further improve results by considering both coherent and incoherent backscatter contributions from the snow and ice layers.

Major challenges for radar altimetry: off-nadir scattering

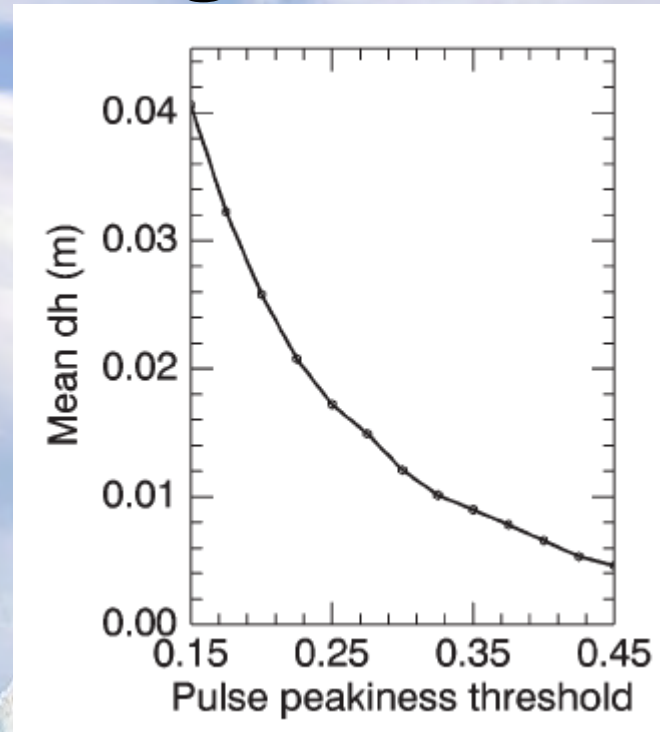
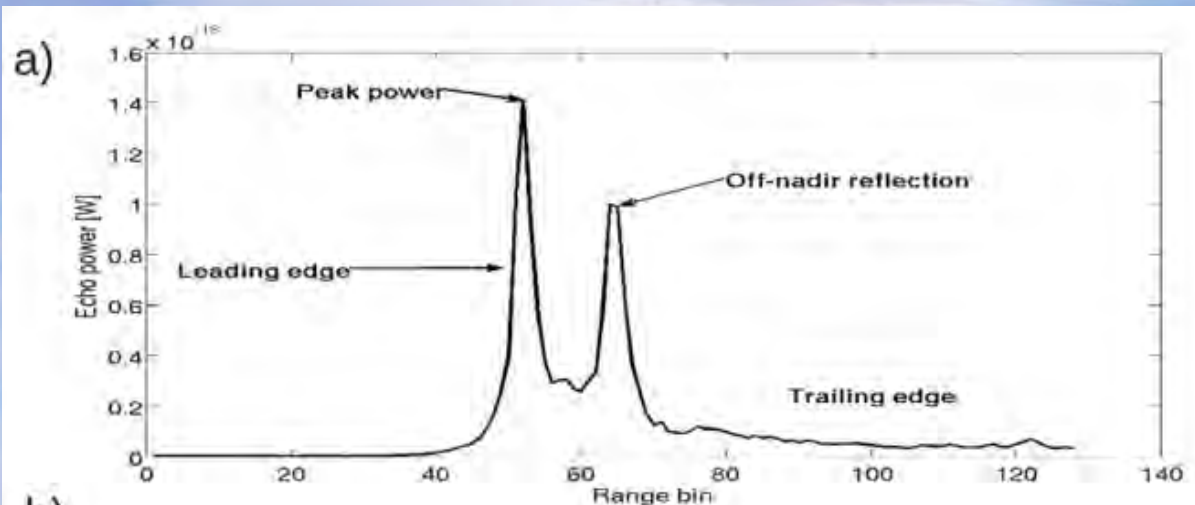

Off-nadir scattering from smooth surfaces causes problems in tracking of the returns. Off-nadir returns also bias the retrieval of sea surface height, recently quantified using CryoSat-2 data in Armitage and Davidson, 2014.

Major challenges for radar altimetry: backscatter from snow layer

$$\Psi(t) = P_t(\tau) \otimes I(\tau) \otimes p(\tau) \otimes v(\tau)$$

$$v(\tau) = \left\{ \begin{array}{l} 0, \tau < -\frac{2h_s}{c_{\text{snow}}} \\ \sigma_{\text{surf-snow}}^0 \delta\left(\tau + \frac{2h_s}{c_{\text{snow}}}\right) + \sigma_{\text{vol-snow}}^0 k_{e\text{-snow}} \\ \exp\left[-c_{\text{snow}} k_{e\text{-snow}} \left(\tau + \frac{2h_s}{c_{\text{snow}}}\right)\right], \\ 0 < \tau \leq \frac{-2h_s}{c_{\text{snow}}} \\ \sigma_{\text{surf-ice}}^0 k_{t\text{-snow}}^2 \exp\left[-k_{e\text{-snow}} h_s / 2\right] \delta(\tau) \\ + \sigma_{\text{vol-ice}}^0 k_{e\text{-ice}} \exp\left[-k_{e\text{-snow}} h_s / 2 - c_{\text{ice}} k_{e\text{-ice}} \tau\right], \\ \tau \geq 0 \end{array} \right.$$

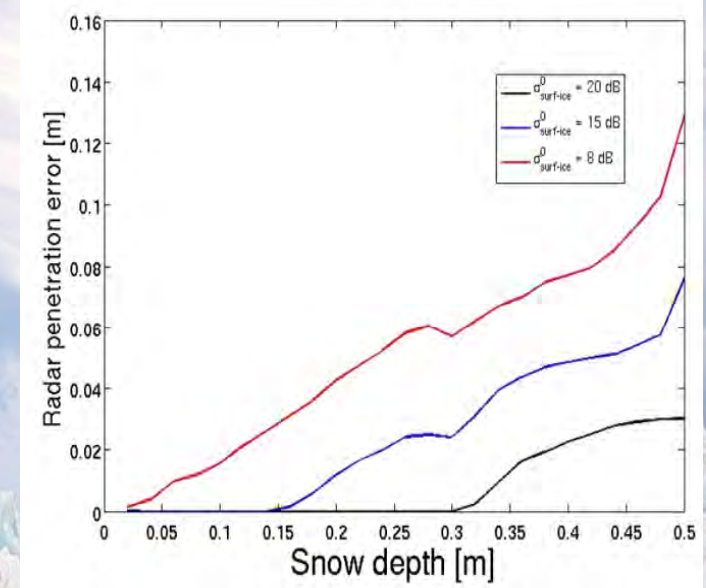

Backscatter from the snow layer is currently seen as a major issue. Approaches have largely been to estimate errors, which are largely a function of the backscatter properties of snow and ice and the snow depth.

Major remaining challenge for altimetry: snow depth on sea ice

For radar, errors due to penetration are dependent on the snow depth and surface and volume backscatter coefficients

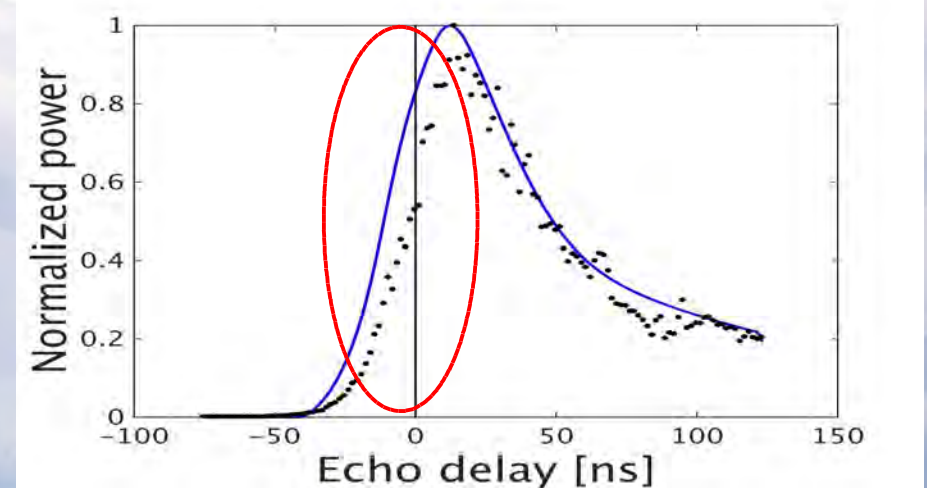
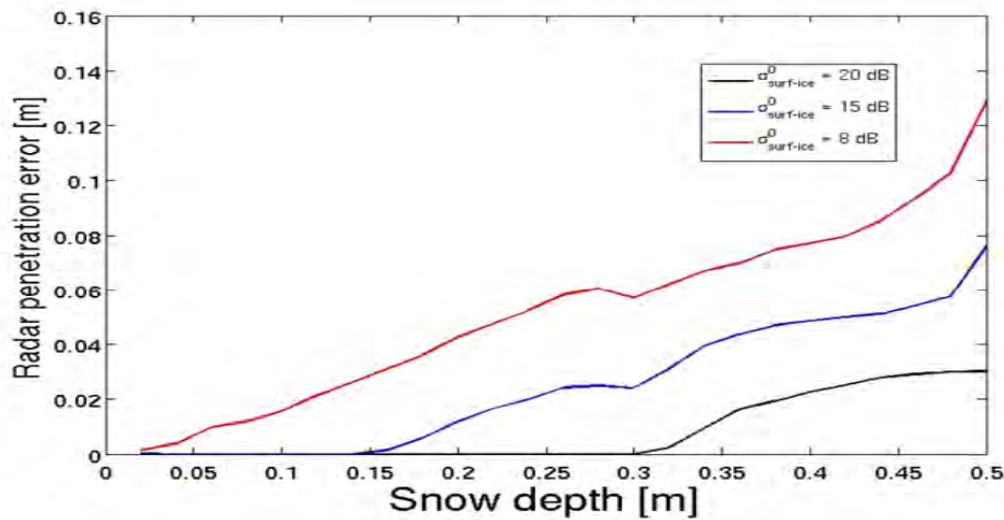

For radar, snow depth is needed to determine speed of light correction:

$$h_c = h_s \left(1 - \frac{c_{\text{snow}}}{c} \right)$$

For both laser and radar thickness retrievals snow depth on sea ice uncertainties are one of the largest sources of error in data sets

Snow depth on sea ice through data assimilation

Many different observations of snow depth on sea ice available which can be combined using data assimilation

All data sets have error covariances which need to be robustly quantified before implemented in a data assimilation system

Ongoing work toward an assimilation method which includes temporal information to be used in CryoSat-2 retrievals over full sea ice growth season

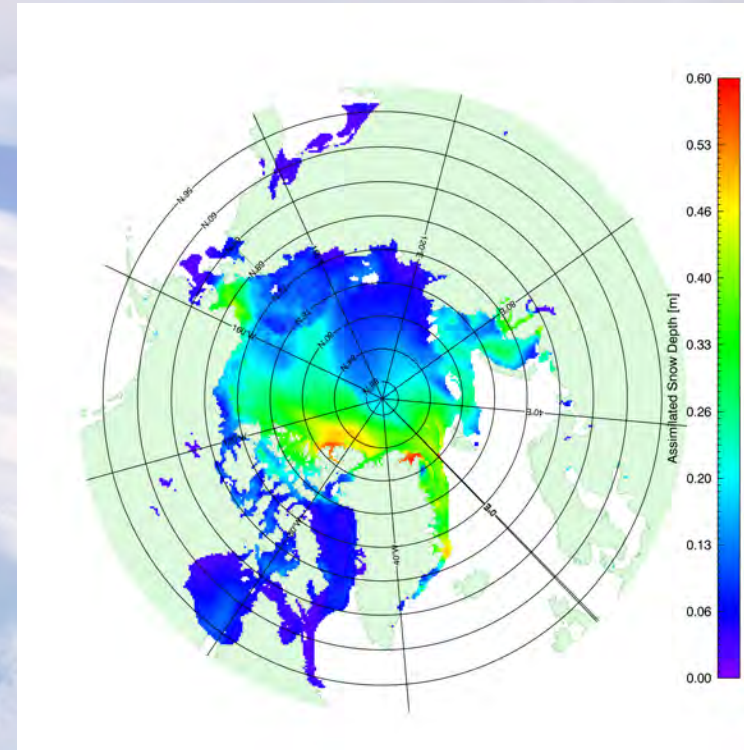

March 2015 snow depth from optimal interpolation of IceBridge snow radar and MERRA

$$x^a = x^b + W (x^o - x^b)$$

$$W = P^a (R_{obs} + P^b)^{-1}$$

Major challenges for all altimetry: snow and sea ice density

Wide discrepancy in sea ice density values used, especially between first year and multi-year ice

Sea ice density values currently used will introduce ~1 m in retrieved thickness

Snow density well observed in central Arctic from Warren climatology

$$h_i = \frac{\rho_w}{\rho_w - \rho_i} fb + \frac{\rho_s}{\rho_w - \rho_i} h_s$$



Summary of major challenges for radar altimetry

- Waveform tracking

- Ongoing improvements through incorporation of physics of radar return

- Absorption

- Not an issue in the Arctic with cold temperatures, may be dominating factor limiting feasibility of Antarctic retrievals

- Surface and volume backscatter from snow

- New results quantifying errors, potential solutions through incorporation of physical model

- Off-nadir scattering

- Addressed through use of CryoSat-2 phase information to determine quantitative biases in data

A snapshot of the current state of the Arctic

January 2015 –
CryoSat-2 freeboard

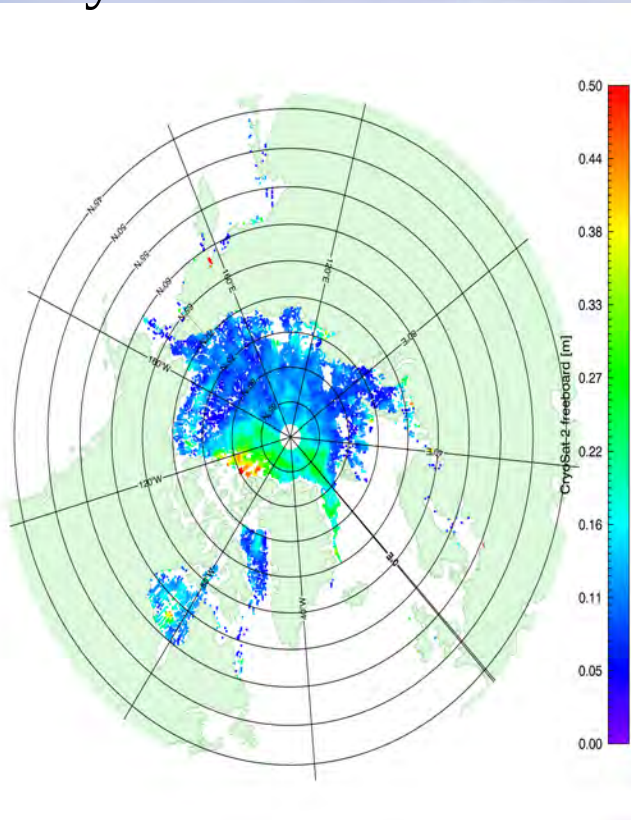

February 2015 –
CryoSat-2 freeboard

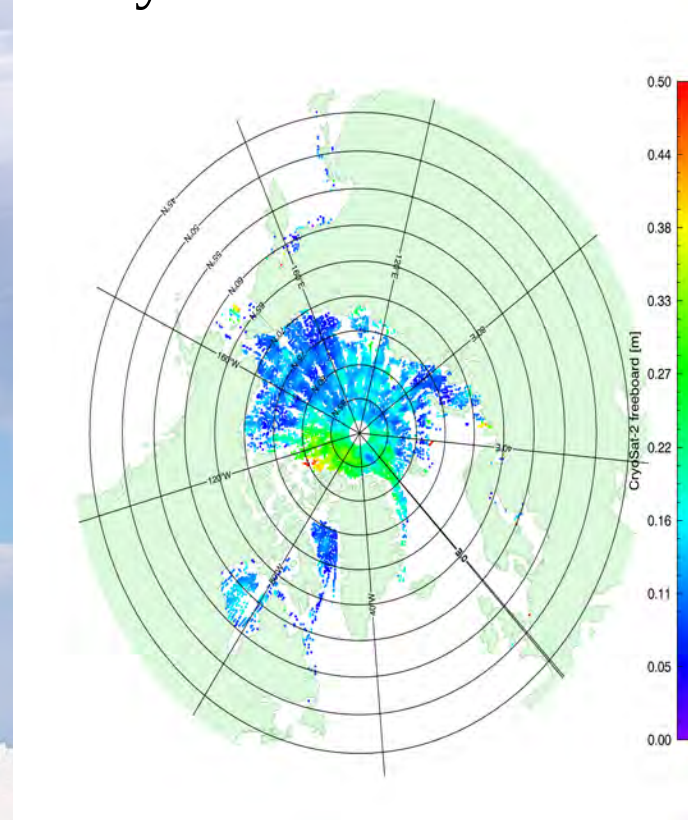

March 2015 –
IceBridge snow

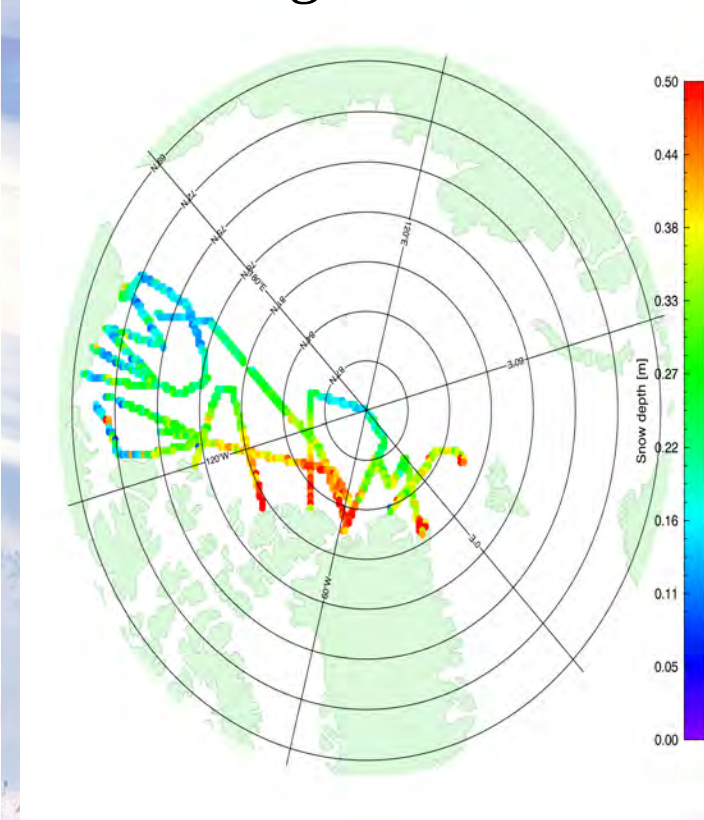

CryoSat-2 processing underway, conversion to Baseline C processor
caused some delays

IceBridge freeboard and thickness processing underway

Full release of data products anticipated next week

Conclusion

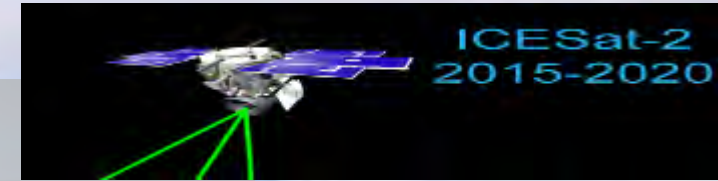

- Continued improvements are being made in the methods used for the retrieval of sea ice thickness to reconcile the laser and radar altimetry records, the IceBridge mission is providing a key link
- Fast and public availability of data is now being used to document sea ice changes, improve modeling physics, and enable seasonal sea ice forecasting for greater societal benefit
- Need to assess big picture questions: What is the future of Arctic sea ice? How will changes to the ice cover impact the climate?

Thank you



Today's presentation will be archived online.

A link will be posted on the
SIPN webpage:
<http://www.arcus.org/sipn>

